

**SPECIFICATION SHEET - kitchen appliances**

<b>BRAND:</b>	<b>Foster</b>	<b>Product Photo:</b>  
<b>ORIGIN:</b>	Italy	
<b>SERIES:</b>	FL	
<b>PRODUCT DESCRIPTION:</b>	Built-in multifunction oven 91 L., - 9 cooling programmes w/electronic control, - EasyClean enamel sides, - 220V/50~60Hz 2.9kW	
<b>MODEL No.</b>	7107.642	
<b>FINISH/COLOUR:</b>	Black mirror front	
<b>DIMENSIONS:</b>	Overall: 890 W x 480 H x 538 D mm Opening: 860 W x 475 H x 550 D mm	
<b>OPTIONAL MATCHING PARTS:</b>		

**Technical Informations:**

**voltage/frequency :** 220V/50-60Hz 1 Phase  
**total power :** 2.9 kW

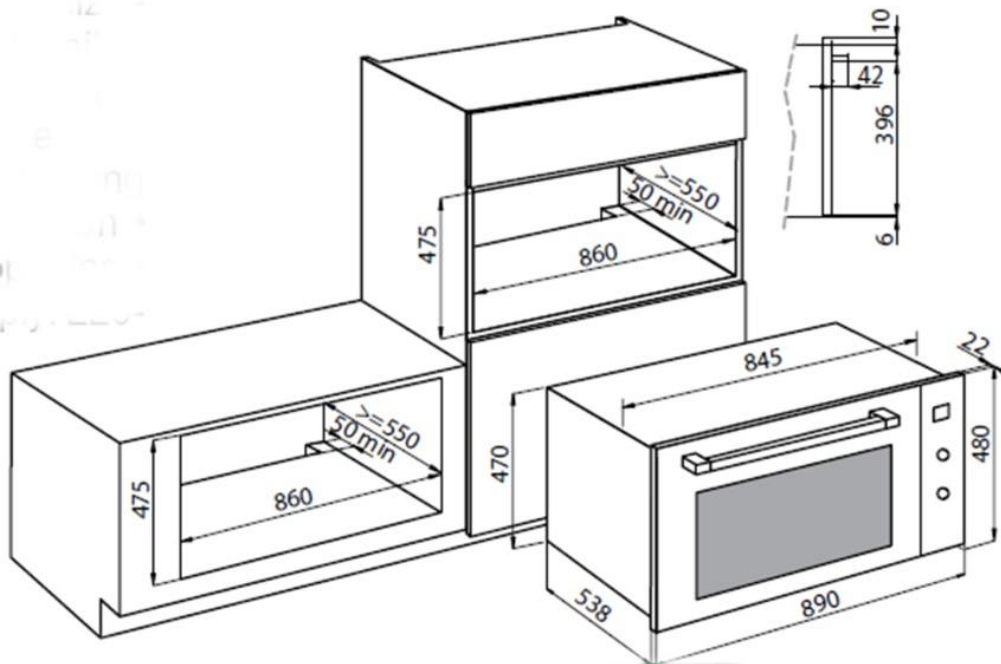

**Minimum 200mm<sup>2</sup> ventilation space at back of housing unit must be required.**

<b>REMINDER:</b>	Do not use abrasive or aggressive cleaners and or contain chlorine or hydrochloric acid solution for cleaning.
	Sufficient ventilation must be provided for oven, microwave, steamer & hobs according to requirement.
	All information stated above are solely for reference only, and should be based on the actual submission sample. Dimensions and specifications are subject to change without prior notice.